

CHO-SORB EMI Ferrites

Cost effective CHO-SORB EMI ferrites reduce conducted emissions and ESD susceptibility on signal lines and power cables without affecting data transmission. They are widely used in computers, printers, key-boards, PBXs, CATVs, radio and television receivers, medical electronics, and data communications equipment. Unlike cable shields, CHO-SORB attenuators do not require grounding.

Easily installed CHO-SORB attenuators are made of specially formulated soft ferrite material containing various metallic oxides, primarily iron oxide. They possess two principle characteristics useful for controlling emissions: high magnetic permeability, which concentrates magnetic fields, and high electrical resistivity, which limits the flow of electrical current in the field.

CHO-SORB nickel zinc material is recommended for unwanted signals between 30 and 300 MHz and high frequency broadband transformers.

CHO-SORB ferrite attenuators are designed to absorb extraneous and unwanted energy on cable and circuit traces. Low frequency and DC see only the conductor and are unimpeded. High frequency energy couples with the CHO-SORB attenuator, cre-



ating an impedance with inductive and resistive qualities.

When a conductor is surrounded by a ferrite attenuator, low frequency signals are transmitted without any loss. High frequency signals encounter inductive resistance due to the ferrite material's permeability. This resistance reduces the conducted current and introduces an insertion loss. At still higher frequencies, the permeability of the ferrite material decreases and the inductive resistance falls. Here,

the resistive characteristics dominate and the resistive quality of the ferrite assumes control of providing the insertion loss for dissipating EMI.

Ordering Procedure

Standard CHO-SORB cable, surface mount and bead-on-lead ferrites are featured on the following pages. All configurations, including attachment clamps, are available through authorized Chomerics distributors for quick, off-the-shelf delivery.

Table 1

TYPICAL PROPERTIES – CHO-SORB EMI FERRITES		
Property	Units	83-10-XXXX-1000
Material	—	Nickel Zinc
Initial Permeability @ B <10 Gauss, m_1	—	850
Flux Density @ (B) @ 10 Oersteds	Gauss	2750
Residual Flux Density	Gauss	1200
Loss Factor (\tan/m_1)	—	120×10^{-6} @ 1 MHz
Curie Temperature	°C	>130
Volume Resistivity	ohm-cm	10^5
Temperature Coefficient of m_1 (20-70°C)	%/°C	1.0
Recommended Frequency Range	MHz	30-200



A CHO-SORB Attenuator Evaluation Kit is also available.

CHO-SORB EMI Ferrites Kit
Part Number: 83-10-KIT-1000

SLEEVE BEADS

Impedance-Frequency Characteristics
P/N 83-10-M460-1000

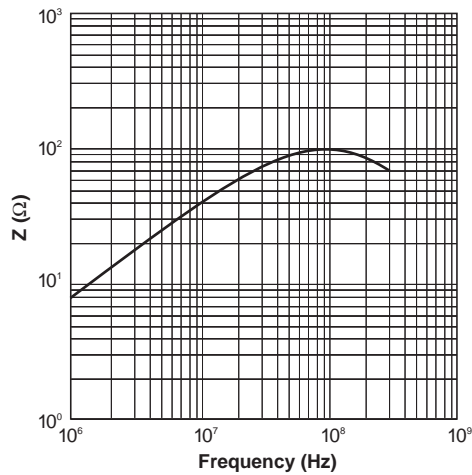
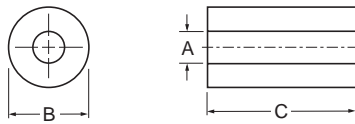

Table 5

Part Number	A (I.D.)	Dimensions - Inches (mm)		Impedance (ohms)*	
		B (O.D.)	C (Length)	@ 25 MHz ±20%	@ 100 MHz ±20%
83-10-M12886-1000	0.032±0.006 (0.80±0.15)	0.098±0.006 (2.50±0.15)	0.158±0.012 (4.00±0.30)	33	52
83-10-M12887-1000	0.032±0.006 (0.80±0.15)	0.138±0.006 (3.50±0.15)	0.552±0.016 (14.00±0.40)	144	21
83-10-M12888-1000	0.032±0.006 (0.80±0.15)	0.386±0.012 (9.80±0.30)	0.449±0.016 (11.40±0.40)	167	256
83-10-M12889-1000	0.040±0.006 (1.00±0.15)	0.119±0.006 (3.00±0.15)	0.119±0.008 (3.00±0.20)	25	47
83-10-M12890-1000	0.040±0.006 (1.00±0.15)	0.138±0.006 (3.50±0.15)	0.315±0.012 (8.00±0.30)	78	111
83-10-M12891-1000	0.048±0.006 (1.20±0.15)	0.119±0.006 (3.00±0.15)	0.119±0.008 (3.00±0.20)	23	44
83-10-M12892-1000	0.048±0.006 (1.20±0.15)	0.138±0.006 (3.50±0.15)	0.158±0.012 (4.00±0.30)	31	46
83-10-M12893-1000	0.048±0.006 (1.20±0.15)	0.138±0.006 (3.50±0.15)	0.197±0.012 (5.00±0.30)	37	55
83-10-M12894-1000	0.048±0.006 (1.20±0.15)	0.138±0.006 (3.50±0.15)	0.237±0.012 (6.00±0.30)	45	73
83-10-M12895-1000	0.048±0.006 (1.20±0.15)	0.138±0.006 (3.50±0.15)	0.276±0.012 (7.00±0.30)	54	84
83-10-M12896-1000	0.052±0.006 (1.30±0.15)	0.138±0.006 (3.50±0.15)	0.197±0.012 (5.00±0.30)	37	61
83-10-M516-1000	0.052±0.006 (1.30±0.15)	0.138±0.006 (3.50±0.15)	0.237±0.012 (6.00±0.30)	42	72
83-10-M12897-1000	0.052±0.006 (1.30±0.15)	0.138±0.006 (3.50±0.15)	0.355±0.012 (9.00±0.30)	62	80
83-10-M442-1000	0.052±0.004 (1.30±0.15)	0.139±0.008 (3.50±0.20)	0.128±0.010 (3.25±0.25)	27	44
83-10-M12898-1000	0.060±0.006 (1.50±0.15)	0.138±0.006 (3.50±0.15)	0.237±0.012 (6.00±0.30)	35	60
83-10-M12899-1000	0.060±0.006 (1.50±0.15)	0.197±0.008 (5.00±0.20)	0.434±0.016 (11.00±0.40)	93	150
83-10-M492-1000	0.062±0.006 (1.57±0.15)	0.200±0.008 (5.00±0.20)	0.438±0.016 (11.10±0.40)	93	148
83-10-M12839-1000	0.071±0.006 (1.80±0.15)	0.138±0.006 (3.50±0.15)	0.197±0.012 (5.00±0.30)	27	48
83-10-M12787-1000	0.079±0.006 (2.00±0.15)	0.158±0.008 (4.00±0.20)	0.079±0.006 (2.00±0.15)	14	37
83-10-M12901-1000	0.079±0.006 (2.00±0.15)	0.158±0.008 (4.00±0.20)	0.158±0.012 (4.00±0.30)	24	48
83-10-M12902-1000	0.079±0.006 (2.00±0.15)	0.158±0.008 (4.00±0.20)	0.197±0.012 (5.00±0.30)	28	51
83-10-M12903-1000	0.079±0.006 (2.00±0.15)	0.158±0.008 (4.00±0.20)	0.276±0.012 (7.00±0.30)	40	64
83-10-M12779-1000	0.079±0.006 (2.00±0.15)	0.158±0.008 (4.00±0.20)	0.394±0.016 (10.00±0.40)	53	80
83-10-M12904-1000	0.085±0.006 (2.15±0.15)	0.197±0.008 (5.00±0.20)	0.709±0.016 (18.00±0.40)	128	147
83-10-M12905-1000	0.091±0.006 (2.29±0.15)	0.191±0.008 (4.80±0.20)	0.250±0.012 (6.35±0.30)	43	80
83-10-M12906-1000	0.091±0.006 (2.30±0.15)	0.197±0.008 (5.00±0.20)	0.197±0.012 (5.00±0.30)	30	55
83-10-M460-1000	0.095±0.006 (2.40±0.15)	0.296±0.008 (7.50±0.20)	0.296±0.012 (7.50±0.30)	60	102
83-10-M12907-1000	0.103±0.006 (2.60±0.15)	0.178±0.008 (4.50±0.20)	0.473±0.016 (12.00±0.40)	49	72
83-10-M12908-1000	0.119±0.008 (3.00±0.20)	0.237±0.008 (6.00±0.20)	0.394±0.016 (10.00±0.40)	52	90
83-10-M12909-1000	0.119±0.008 (3.00±0.20)	0.312±0.008 (7.90±0.20)	0.394±0.016 (10.00±0.40)	68	79
83-10-M12910-1000	0.119±0.008 (3.00±0.20)	0.312±0.008 (7.90±0.20)	0.749±0.016 (19.00±0.40)	130	190
83-10-M12911-1000	0.125±0.008 (3.15±0.20)	0.237±0.008 (6.00±0.20)	0.709±0.016 (18.00±0.40)	100	155
83-10-M12912-1000	0.126±0.008 (3.18±0.20)	0.315±0.008 (8.00±0.20)	0.397±0.016 (10.06±0.40)	67	115
83-10-M12913-1000	0.130±0.008 (3.30±0.20)	0.250±0.008 (6.35±0.20)	0.500±0.016 (12.70±0.40)	67	105
83-10-M12914-1000	0.130±0.008 (3.30±0.20)	0.250±0.008 (6.35±0.20)	0.623±0.016 (15.80±0.40)	76	125
83-10-M12915-1000	0.138±0.008 (3.50±0.20)	0.473±0.012 (12.00±0.30)	0.906±0.020 (23.00±0.50)	210	328
83-10-M12916-1000	0.158±0.008 (4.00±0.20)	0.312±0.008 (7.90±0.20)	0.504±0.016 (12.80±0.40)	66	107
83-10-M12788-1000	0.158±0.008 (4.00±0.20)	0.315±0.012 (8.00±0.30)	0.158±0.008 (4.00±0.20)	23	46
83-10-M12917-1000	0.170±0.008 (4.30±0.20)	0.256±0.008 (6.50±0.20)	0.394±0.016 (10.00±0.40)	34	62

*Based upon single turn impedance measurement, using an HP 4193A.

Table 5 continued

Part Number	Dimensions - Inches (mm)			Impedance (ohms)*	
	A (I.D.)	B (O.D.)	C (Length)	@ 25 MHz ±20%	@ 100 MHz ±20%
83-10-M12918-1000	0.170±0.008 (4.30±0.20)	0.453±0.012 (11.50±0.30)	0.788±0.020 (20.00±0.50)	148	210
83-10-M12919-1000	0.170±0.008 (4.30±0.20)	0.453±0.012 (11.50±0.30)	1.024±0.024 (26.00±0.60)	190	270
83-10-M12920-1000	0.178±0.010 (4.50±0.25)	0.367±0.012 (9.30±0.30)	0.375±0.012 (9.50±0.30)	53	98
83-10-M12921-1000	0.193±0.008 (4.88±0.20)	0.486±0.012 (12.30±0.30)	1.000±0.024 (25.40±0.60)	172	264
83-10-M12789-1000	0.197±0.008 (5.00±0.20)	0.355±0.012 (9.00±0.30)	0.119±0.010 (3.00±0.25)	21	54
83-10-M245-1000	0.197±0.010 (5.00±0.25)	0.375±0.012 (9.50±0.30)	0.410±0.016 (10.40±0.40)	53	81
83-10-M446-1000	0.197±0.010 (5.00±0.25)	0.375±0.012 (9.50±0.30)	0.571±0.016 (14.50±0.40)	75	121
83-10-M445-1000	0.197±0.010 (5.00±0.25)	0.375±0.012 (9.50±0.30)	0.626±0.016 (15.88±0.40)	74	103
83-10-M454-1000	0.197±0.010 (5.00±0.25)	0.375±0.012 (9.50±0.30)	0.749±0.016 (19.00±0.40)	9	135
83-10-M12923-1000	0.197±0.010 (5.00±0.25)	0.375±0.012 (9.50±0.30)	0.768±0.016 (19.50±0.40)	98	153
83-10-M828-1000	0.197±0.008 (5.00±0.20)	0.380±0.010 (9.65±0.25)	0.191±0.018 (4.83±0.45)	25	47
83-10-M12924-1000	0.197±0.008 (5.00±0.20)	0.394±0.012 (10.00±0.30)	0.394±0.016 (10.00±0.40)	54	85
83-10-M12925-1000	0.197±0.010 (5.00±0.25)	0.434±0.012 (11.00±0.30)	0.729±0.016 (18.50±0.40)	113	178
83-10-M12926-1000	0.197±0.010 (5.00±0.25)	0.434±0.012 (11.00±0.30)	0.985±0.024 (25.00±0.60)	145	230
83-10-M12927-1000	0.205±0.010 (5.20±0.25)	0.375±0.012 (9.50±0.30)	0.375±0.012 (9.50±0.30)	45	76
83-10-M12928-1000	0.205±0.010 (5.20±0.25)	0.375±0.012 (9.50±0.30)	0.394±0.016 (10.00±0.40)	48	74
83-10-M12853-1000	0.217±0.010 (5.50±0.25)	0.414±0.012 (10.50±0.30)	0.788±0.020 (20.00±0.50)	95	135
83-10-M12780-1000	0.221±0.010 (5.60±0.25)	0.473±0.012 (12.00±0.30)	0.788±0.020 (20.00±0.50)	119	175
83-10-M12929-1000	0.221±0.010 (5.60±0.25)	0.473±0.012 (12.00±0.30)	1.182±0.028 (30.00±0.70)	180	260
83-10-M12930-1000	0.229±0.010 (5.80±0.25)	0.375±0.012 (9.50±0.30)	0.394±0.016 (10.00±0.40)	38	68
83-10-M12931-1000	0.229±0.010 (5.80±0.25)	0.749±0.020 (19.00±0.50)	1.241±0.032 (31.50±0.80)	291	423
83-10-M12932-1000	0.237±0.012 (6.00±0.30)	0.315±0.008 (8.00±0.20)	0.386±0.012 (9.80±0.30)	35	55
83-10-M12933-1000	0.237±0.012 (6.00±0.30)	0.394±0.012 (10.00±0.30)	0.394±0.016 (10.00±0.40)	38	66
83-10-M12934-1000	0.237±0.012 (6.00±0.30)	0.394±0.012 (10.00±0.30)	0.552±0.016 (14.00±0.40)	45	73
83-10-M12790-1000	0.237±0.008 (6.00±0.20)	0.473±0.012 (12.00±0.30)	0.158±0.012 (4.00±0.30)	24	47
83-10-M12935-1000	0.250±0.012 (6.35±0.30)	0.560±0.016 (14.20±0.40)	0.591±0.016 (15.00±0.40)	92	146
83-10-M246-1000	0.250±0.012 (6.35±0.30)	0.560±0.016 (14.20±0.40)	1.123±0.024 (28.50±0.60)	164	255
83-10-M12936-1000	0.264±0.012 (6.70±0.30)	0.386±0.012 (9.80±0.30)	0.532±0.016 (13.50±0.40)	43	91
83-10-M12937-1000	0.276±0.012 (6.99±0.30)	0.591±0.016 (14.99±0.40)	0.749±0.016 (19.00±0.40)	107	171
83-10-M12823-1000	0.276±0.012 (6.99±0.30)	0.591±0.016 (14.99±0.40)	1.100±0.016 (27.94±0.40)	151	237
83-10-M636-1000	0.276±0.012 (6.99±0.30)	0.617±0.016 (15.65±0.40)	1.125±0.024 (28.57±0.60)	164	258
83-10-M12939-1000	0.276±0.012 (7.00±0.30)	0.394±0.012 (10.00±0.30)	0.394±0.016 (10.00±0.40)	31	57
83-10-M12940-1000	0.276±0.012 (7.00±0.30)	0.473±0.012 (12.00±0.30)	0.591±0.016 (15.00±0.40)	60	92
83-10-M12941-1000	0.276±0.012 (7.00±0.30)	0.560±0.016 (14.20±0.40)	0.591±0.016 (15.00±0.40)	78	116
83-10-M12942-1000	0.276±0.012 (7.00±0.30)	0.560±0.016 (14.20±0.40)	0.926±0.020 (23.50±0.50)	127	204
83-10-M12781-1000	0.276±0.012 (7.00±0.30)	0.560±0.016 (14.20±0.40)	1.123±0.024 (28.50±0.60)	143	243
83-10-M12784-1000	0.276±0.012 (7.00±0.30)	0.630±0.016 (16.00±0.40)	1.103±0.024 (28.00±0.60)	174	247
83-10-M12782-1000	0.310±0.012 (7.87±0.30)	0.626±0.016 (15.80±0.40)	1.125±0.024 (28.57±0.60)	148	241
83-10-M12943-1000	0.312±0.012 (7.90±0.30)	0.623±0.016 (15.80±0.40)	0.630±0.016 (16.00±0.40)	74	117
83-10-M827-1000	0.312±0.010 (7.92±0.25)	0.626±0.030 (15.80±0.75)	0.562±0.014 (14.27±0.35)	79	121
83-10-M12791-1000	0.315±0.012 (8.00±0.30)	0.493±0.012 (12.50±0.30)	0.250±0.012 (6.35±0.30)	27	52
83-10-12819-1000	0.315±0.012 (8.00±0.30)	0.493±0.012 (12.50±0.30)	0.493±0.016 (12.50±0.40)	42	72
83-10-M12945-1000	0.315±0.012 (8.00±0.30)	0.560±0.016 (14.20±0.40)	0.591±0.016 (15.00±0.40)	63	107
83-10-M12864-1000	0.315±0.012 (8.00±0.30)	0.560±0.016 (14.20±0.40)	1.123±0.024 (28.50±0.60)	128	195
83-10-M12947-100	0.315±0.012 (8.00±0.30)	0.601±0.016 (15.25±0.40)	1.103±0.024 (28.00±0.60)	122	180
83-10-M12793-1000	0.323±0.010 (8.20±0.25)	0.650±0.012 (16.50±0.30)	0.630±0.016 (16.00±0.40)	87	145
83-10-M12871-1000	0.327±0.012 (8.30±0.30)	0.689±0.016 (17.50±0.40)	1.123±0.024 (28.50±0.60)	148	242
83-10-M12948-1000	0.335±0.012 (8.50±0.30)	0.473±0.012 (12.00±0.30)	0.591±0.016 (15.00±0.40)	45	85
83-10-M12840-1000	0.345±0.012 (8.76±0.30)	0.673±0.016 (17.00±0.40)	1.000±0.024 (25.40±0.60)	122	180
83-10-M12783-1000	0.355±0.012 (9.00±0.30)	0.630±0.016 (16.00±0.40)	0.670±0.016 (17.00±0.40)	61	115
83-10-M12949-1000	0.355±0.012 (9.00±0.30)	0.630±0.016 (16.00±0.40)	0.788±0.020 (20.00±0.50)	98	124
83-10-M12785-1000	0.355±0.012 (9.00±0.30)	0.630±0.016 (16.00±0.40)	1.103±0.024 (28.00±0.60)	104	178
83-10-M12950-1000	0.355±0.012 (9.00±0.30)	0.630±0.016 (16.00±0.40)	1.123±0.024 (28.50±0.60)	105	195
83-10-M12794-1000	0.375±0.012 (9.50±0.30)	0.689±0.016 (17.50±0.40)	0.250±0.012 (6.35±0.30)	31	53
83-10-M248-1000	0.375±0.012 (9.50±0.30)	0.689±0.016 (17.50±0.40)	1.123±0.024 (28.50±0.60)	115	170

*Based upon single turn impedance measurement, using an HP 4193A.

continued



Table 5 continued

Part Number	Dimensions - Inches (mm)			Impedance (ohms)*	
	A (I.D.)	B (O.D.)	C (Length)	@ 25 MHz ±20%	@ 100 MHz ±20%
83-10-M12951-100	0.375±0.012 (9.50±0.30)	0.689±0.016 (17.50±0.40)	1.378±0.032 (35.00±0.80)	152	253
83-10-M12952-1000	0.394±0.016 (10.00±0.40)	0.601±0.016 (15.25±0.40)	1.123±0.024 (28.50±0.60)	81	128
83-10-M12953-1000	0.394±0.016 (10.00±0.40)	0.630±0.016 (16.00±0.40)	1.103±0.024 (28.00±0.60)	91	156
83-10-M12954-1000	0.394±0.016 (10.00±0.40)	0.689±0.016 (17.50±0.40)	1.575±0.036 (40.00±0.90)	123	232
83-10-M12795-1000	0.394±0.012 (10.00±0.40)	0.709±0.016 (18.00±0.40)	0.394±0.012 (10.00±0.30)	47	77
83-10-M12955-1000	0.394±0.016 (10.00±0.40)	0.709±0.020 (18.00±0.50)	1.103±0.024 (28.00±0.60)	124	209
83-10-M12956-1000	0.394±0.016 (10.00±0.40)	0.709±0.020 (18.00±0.50)	1.142±0.024 (29.00±0.60)	128	210
83-10-M12957-1000	0.400±0.016 (10.16±0.40)	0.733±0.020 (18.60±0.50)	0.985±0.024 (25.00±0.60)	115	178
83-10-M249-1000	0.400±0.016 (10.16±0.40)	0.736±0.020 (18.60±0.50)	1.125±0.024 (28.57±0.60)	126	201
83-10-M12796-1000	0.402±0.016 (10.20±0.40)	0.808±0.020 (20.50±0.50)	0.394±0.012 (10.00±0.30)	53	86
83-10-M12792-1000	0.414±0.012 (10.50±0.30)	0.591±0.012 (15.00±0.30)	0.473±0.012 (12.00±0.30)	37	62
83-10-M12820-1000	0.422±0.016 (10.70±0.40)	0.689±0.016 (17.50±0.40)	1.123±0.024 (28.50±0.60)	90	150
83-10-M250-1000	0.506±0.016 (12.83±0.40)	1.021±0.019 (25.90±0.46)	1.125±0.030 (28.57±0.76)	127	195
83-10-M12958-1000	0.512±0.016 (13.00±0.40)	0.749±0.020 (19.00±0.50)	1.142±0.024 (29.00±0.60)	60	105
83-10-M12797-1000	0.532±0.012 (13.50±0.30)	0.867±0.020 (22.00±0.50)	0.315±0.012 (8.00±0.30)	37	78
83-10-M637-1000	0.543±0.016 (13.77±0.40)	1.123±0.020 (28.50±0.46)	1.125±0.030 (28.57±0.76)	158	250
83-10-M12798-1000	0.552±0.012 (14.00±0.30)	0.867±0.020 (22.00±0.50)	0.394±0.012 (10.00±0.30)	42	84
83-10-M12772-1000	0.591±0.012 (15.00±0.30)	0.985±0.016 (25.00±0.40)	0.473±0.012 (12.00±0.30)	53	97
83-10-M12773-1000	0.630±0.016 (16.00±0.40)	1.103±0.024 (28.00±0.60)	0.512±0.012 (13.00±0.30)	63	112
83-10-M825-1000	0.749±0.020 (19.00±0.50)	1.143±0.030 (29.00±0.75)	0.295±0.010 (7.49±0.25)	31	75
83-10-M12774-1000	0.749±0.016 (19.00±0.40)	1.221±0.020 (31.00±0.50)	0.315±0.012 (8.00±0.30)	36	79
83-10-M12775-1000	1.079±0.024 (27.40±0.60)	1.599±0.032 (40.60±0.80)	0.591±0.016 (15.00±0.40)	55	106
83-10-M256-1000	1.418±0.0320 (36.00±0.75)	2.418±0.052 (61.40±1.30)	0.504±0.020 (12.80±0.50)	58	124

* Based upon single turn impedance measurement, using an HP 4191A.

FLAT SOLID CABLE CORE

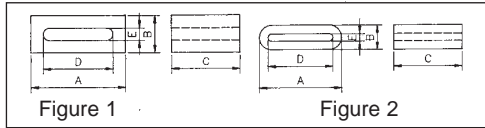

Table 6

Part Number	Dimensions - Inches (mm)					Impedance (ohms)	
	A	B	C	D	E	@ 25 MHz ±20%	@ 100 MHz ±20%
83-10-M12761-1000	0.63±0.016 (16.00±0.40)	0.197±0.138 (5.00±0.35)	0.315±0.016 (8.00±0.40)	0.453±0.016 (11.50±0.40)	0.02±.012 (0.50±0.30)	29	58
83-10-M12762-1000	1.122±0.04 (28.50±1.00)	0.256±0.012 (6.50±0.30)	0.315±0.016 (8.00±0.40)	0.925±0.02 (23.50±0.50)	0.034±.012 (0.85±0.30)	28	65
83-10-M12763-1000	1.22±0.04 (31.00±1.00)	0.197±0.012 (5.00±0.30)	0.472±0.012 (12.00±0.30)	1.063±0.028 (27.00±0.70)	0.034±.012 (0.85±0.30)	32	86
83-10-M12764-1000	1.312±0.04 (33.50±1.00)	0.256±0.012 (6.50±0.30)	0.472±0.012 (12.00±0.30)	1.063±0.028 (27.00±0.70)	0.055±0.016 (1.40±0.40)	30	66
83-10-M12765-1000	1.575±0.03 (40.00±0.70)	0.256±0.012 (6.50±0.30)	0.472±0.012 (12.00±0.30)	1.378±0.028 (35.00±0.70)	0.055±0.016 (1.40±0.40)	28	69
83-10-M12766-1000	1.78±0.04 (45.20±1.00)	0.256±0.012 (6.50±0.30)	0.472±0.012 (12.00±0.30)	1.575±0.028 (40.00±0.70)	0.055±0.016 (1.40±0.40)	28	68
83-10-M12767-1000	1.953±0.04 (49.60±1.00)	0.256±0.012 (6.50±0.30)	0.472±0.012 (12.00±0.30)	1.732±0.032 (44.00±0.80)	0.055±0.016 (1.40±0.40)	25	69
83-10-M12834-1000	2.268±0.039 (57.60±1.00)	0.756±0.012 (6.50±0.30)	0.472±0.012 (12.00±0.30)	2.047±0.032 (52.00±0.80)	0.055±0.016 (1.40±0.40)	26	75
83-10-M12768-1000*	2.362±0.04 (60.00±1.00)	0.472±0.016 (12.00±0.40)	0.5±0.016 (12.70±0.40)	1.91±0.032 (48.50±0.80)	0.087±0.012 (2.20±0.30)	40	104

*Figure 1 only

FLAT SPLIT CABLE CORE

Impedance-Frequency Characteristics
P/N 83-10-F255-1000

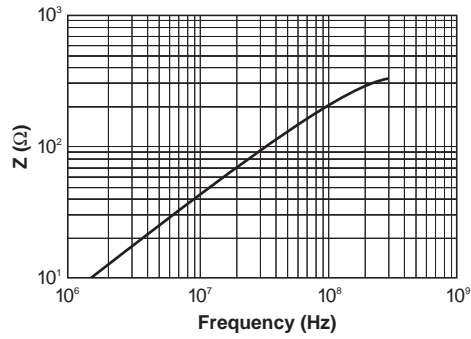
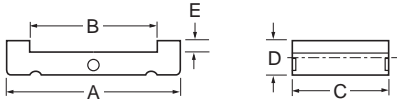
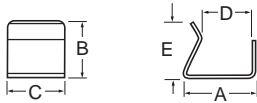

Table 7

Part Number	Dimensions - Inches (mm)					Impedance (ohms)	
	A	B	C	D	E	@ 25 MHz ±20%	@ 100 MHz -20%
83-10-F254-1000C	2.500 (63.5±1.3)	2.050 (52.1±1.1)	1.125 (28.57±0.8)	0.250 (6.35±0.25)	0.033 (0.84±0.2)	70	235
83-10-F255-1000C	3.000 (76.2±1.5)	2.570 (65.28±1.3)	1.125 (28.57±0.8)	0.250 (6.35±0.25)	0.033 (0.84±0.2)	60	215
83-10-M12769-1000C	1.50 (38.00±1.00)	1.05 (26.60±0.70)	1.00 (25.40±0.70)	0.250 (6.35±0.25)	0.033 (0.84±0.2)	105	175
83-10-M12770-1000C	1.775 (45.00±1.00)	1.355 (34.40±0.70)	1.125 (28.50±0.70)	0.250 (6.35±0.25)	0.033 (0.84±0.2)	102	189
83-10-M12771-1000C	2.17 (55.10±1.20)	1.72 (43.70±1.00)	1.125 (28.50±0.70)	0.250 (6.35±0.25)	0.033 (0.84±0.2)	80	181

CLIPS FOR FLAT SPLIT CABLE CORE



Material: 0.020 inch (0.5 mm) High Carbon Steel
Finish: Zinc Electroplate

Table 8

Part Number	Dimensions - Inches (mm)					Fits CHO-SORB Part Number
	A	B	C	D	E	
83-10-C0005-1000	0.618 (15.7)	0.280 (7.1)	0.500 (12.7)	0.457 (11.6)	0.382 (9.7)	83-10-F254-1000C 83-10-F255-1000C 83-10-M12769-1000C 83-10-M12770-1000C 83-10-M12771-1000C

continued

SQUARE SPLIT BEAD ASSEMBLY

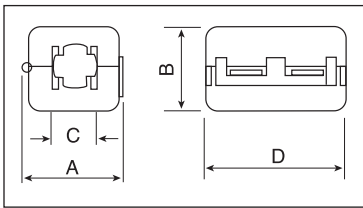

Case Material: Nylon 6/6,
Flammability Rating: UL 94V-2

Table 10

Part Number	Dimensions - Inches (mm)				Max. Cable Gauge	Impedance (ohms)	
	A	B	C	D		@25 MHz ±20%	@100 MHz ±20%
83-10-Y377-1000	1.24±0.04 (31.50±1.00)	1.22±0.04 (31.00±1.00)	0.55±0.04 (14.00±1.00)	1.28±0.04 (32.50±1.00)	0.512 (13.00)	137	268
83-10-Y379-1000	0.80±0.04 (20.50±1.00)	0.79±0.04 (20.10±1.00)	0.30±0.04 (7.60±1.00)	1.28±0.04 (32.50±1.00)	0.256 (6.50)	133	308
83-10-Y850-1000	1.00±0.04 (25.50±1.00)	0.925±0.04 (23.50±1.00)	0.453±0.04 (11.50±1.00)	1.28±0.04 (32.50±1.00)	0.394 (10.00)	124	245
83-10-M12818-1000	0.59±0.04 (15.00±1.0)	0.55±0.04 (14.00±1.0)	0.236±0.04 (6.00±1.00)	0.906±0.04 (23.00±1.0)	0.197 (5.00)	103	174

NOTE: Dimensions A, B, C and D are for the case.

ROUND SPLIT BEAD ASSEMBLY

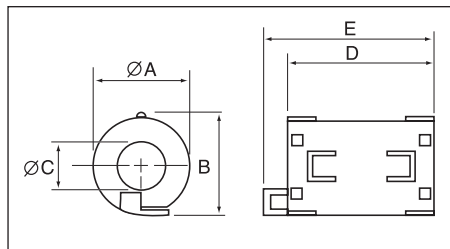

Fig. 1

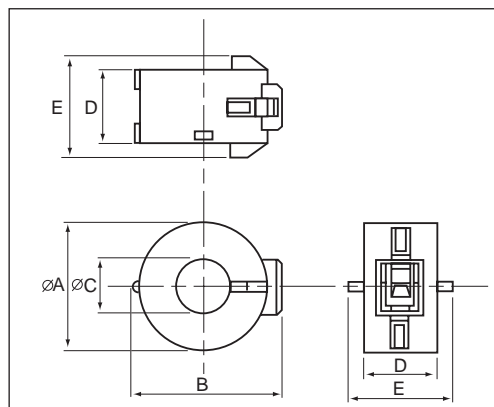

Fig. 2

Case Material: Nylon 6/6,
Flammability Rating: UL 94V-2

Table 11

Part Number	Figure	Dimensions - inches (mm)					Max. Cable Gauge	Impedance (ohms)*	
		A (dia)	B	C (dia)	D	E		@25MHz ±20%	@100 MHz ±20%
83-10-M12799-1000	1	0.77±0.04 (19.5±1.0)	0.81±0.04 (20.5±1.0)	0.39±0.04 (10.0±1.0)	1.24±0.04 (31.5±1.0)	1.40±0.04 (35.5±1.0)	0.35 (9mm)	120	190
83-10-M12813-1000	2	0.77±0.04 (19.5±1.0)	0.91±0.04 (23.0±1.0)	0.33±0.04 (8.5±1.0)	0.67±0.04 (17.0±1.0)	0.91±0.04 (23.0±1.0)	0.31 (8mm)	60	120
83-10-M12814-1000	2	0.77±0.04 (19.5±1.0)	0.91±0.04 (23.0±1.0)	0.32±0.04 (8.2±1.0)	0.79±0.04 (20.0±1.0)	1.02±0.04 (26.0±1.0)	0.31 (8mm)	75	160
83-10-M12815-1000	2	0.96±0.04 (24.5±1.0)	1.12±0.04 (28.5±1.0)	0.39±0.04 (10.0±1.0)	0.53±0.04 (13.5±1.0)	0.79±0.04 (20.0±1.0)	0.39 (10mm)	50	105
83-10-M12816-1000	2	1.10±0.04 (28.0±1.0)	1.24±0.04 (31.5±1.0)	0.45±0.04 (11.5±1.0)	0.71±0.04 (18.0±1.0)	0.94±0.04 (24.0±1.0)	0.43 (11mm)	70	140
83-10-M12817-1000	2	1.14±0.04 (29.0±1.0)	1.30±0.04 (33.0±1.0)	0.55±0.04 (14.0±1.0)	0.61±0.04 (15.5±1.0)	0.85±0.04 (21.5±1.0)	0.55 (14mm)	45	100

* Based upon single turn impedance measurement using an HP 4191A